

TOSHIBA

Leading Innovation >>>

UNINTERRUPTIBLE POWER SYSTEMS



3 Year
Warranty

G9000 Series

80/100/160/225/300/
500/750 KVA UPS

CT

97%
Efficiency



- Next-Generation IGBT Technology
- True On-Line, Double-Conversion UPS
- Parallel up to Eight Units
- Input Power Factor > 0.99
- Input Current THD < 3%
- Output Power Factor to 1.0
- 100% Unbalanced Load Capability
- Wide Input Voltage Range +15%, -20% (Without Utilizing Batteries)
- High Efficiency for Lower Operational Cost
- Smallest Footprint & Highest Power Density in Industry
- Electronic Battery Isolation for Battery Longevity
- Generator-Friendly Design & Compatibility
- Complete Front-Access for Installation, Operation, & Service
- Handles Leading Power Factor Loads (Without Derating)
- SNMP/Web-Based Monitoring
- Three-Year Warranty for Lower Cost of Ownership

*See specifications on back.

Main Features

The Toshiba G9000 Uninterruptible Power System (UPS) utilizes state-of-the-art design and construction to deliver industry-leading efficiency, reliability, and flexibility to meet today's critical power demands.



100 KVA G9000 UPS

High Efficiency Design Ensures Low Power Loss Even at Minimal Loads

An efficiency greater than 92.5% at 20% loading means lower power losses, reduced air conditioning needs, and reduced utility costs across a wide load range without sacrificing frequency or output voltage stability.

Smallest Footprint/Highest Power Density

The G9000's transformerless design makes it far lighter than conventional UPSs, and gives it a much smaller footprint compared to similar sized UPSs. With its compact size, the G9000 has the highest energy density per square foot of any UPS of similar capacity.

- Fast-switching IGBT control technology delivers up to 97% efficiency.
- Full IGBT rectifier & harmonic input filter reduce input total harmonic distortion (THD) which also reduces heat loss in associated feed equipment & increases component life.
- IGBT DC-DC chopper produces lower DC ripple on the charging circuit, extending battery & capacitor life.
- Hybrid static bypass switch offers efficiency & dependability.
- Improved output voltage regulation provides superior transient response, easily handling 100% step loads without requiring battery support.
- Generator friendly interface allows sizing of 1.1 KW generator capacity per 1.0 UPS KVA load.
- The G9000 has the ability to combine up to eight modules for increased capacity/redundancy.
- Each module is self-contained with its own switching & control intelligence. This control redundancy increases system reliability.
- Toshiba's G9000 is robustly engineered with highest quality components to ensure reliability.

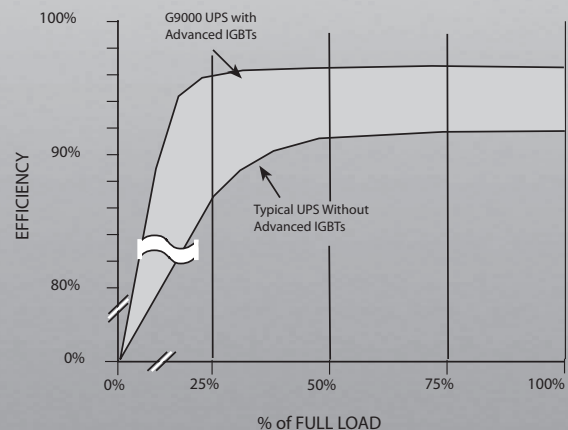

System Configurations

G9000 UPS Applications

- Power Conditioner
- Frequency Converter
- Line-Up-and-Match Backup Power Supplies:
 - VLRA & Wet-Cell Battery System: The robust recharge circuitry of the G9000 allows use of either VLRA or flooded wet-cell batteries without requiring a supplemental charger.
 - Rotary Energy Storage (flywheel): This green energy storage solution offers a twenty-year life expectancy, unlimited recharge cycles, & very low power consumption in ready mode.

Single Module

- Single- or Dual-Source Input
- DC to DC Isolation
- Internal Hybrid Static Bypass Circuit
- Controllable at Local LCD Panel or Through Customer Supplied Interface
- Monitor UPS Locally or Remotely

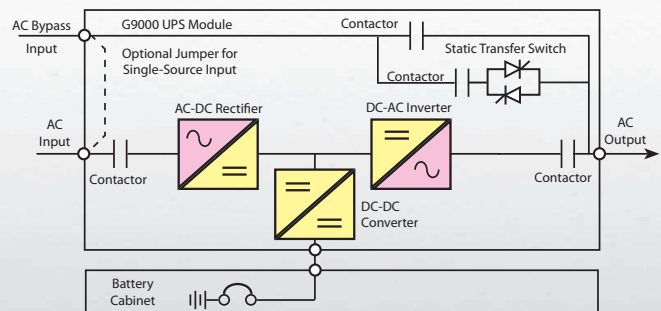

Multi-Module

- Parallel up to Eight Units Without Additional Control Circuitry
- Load Capacity 80 to 4000 KVA
- Distributed Bypass Eliminates Potential Single Point of Failure in Bypass Mode
- Tie Cabinet Requires No Sophisticated Control Circuitry for Ease of Future Expansion
- Both individual modules & the entire system can be monitored & controlled via local displays in each UPS, or through optional System display in TTC
- Load balance & synchronization intelligence is self-contained in each UPS module & not in an external sync controller, increasing system reliability & making expansion/reconfiguration of Parallel multi-module systems easy
- Self-Contained Modular Design for Easy Expansion/Reconfiguration of Parallel
- Multi-Module Installation into Multiple Independent Systems
- Each Module is Self-Contained with own Switching & Control Intelligence, Increasing System Reliability

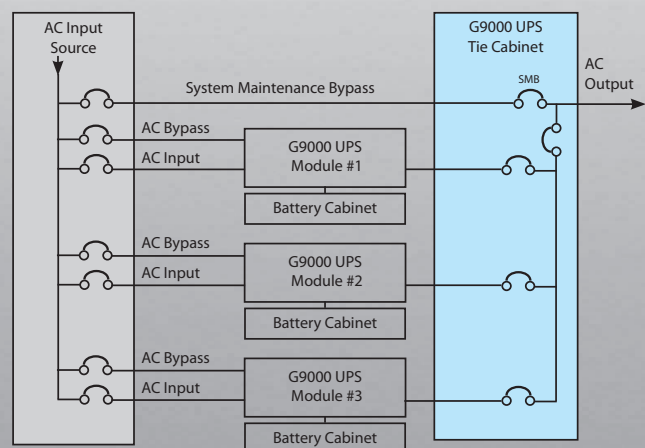

G9000 Options

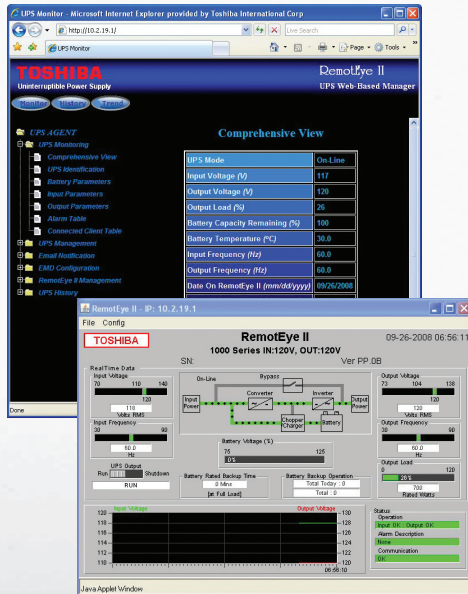

Remote Monitoring Support

The optional RemoteEyeII interface offers remote monitoring & analysis of UPS operation via HTTP & SNMP.

- Detailed, real-time status of UPS
- Email notification of status & events
- Event & alarm history logging
- Remote control of UPS via internet

The optional Industrial Bus ProtoNode protocol adapter supports:

- SNMP
- RTU
- Metasys N2
- AB Ethernet IP
- TCP/IPMODBUS
- MSTP
- BACnet/BACnet IP

An optional hard-wired Remote Status Alarm Panel (RSAP) enables remote monitoring of UPS alarm / status points up to 1000 feet away.



Battery Cabinets & Flywheels

Matching battery cabinets provide uniform appearance to your installation. The G9000 works equally well with either Valve-Regulated Lead Acid (VRLA) or flooded battery-backup. Rotary flywheel backup provides the ultimate in green power combined with long term reliability.

Toshiba Tie Cabinet

The G9000 UPS tie cabinet provides an attractive, simple landing point for a multi-module G9000 system's output. Toshiba's solution is a smaller, lighter option with no control electronics compared to those offered by competitors. An optional five-inch color LCD display is available for centralized monitoring of module and system status as a supplement to individual module monitors.

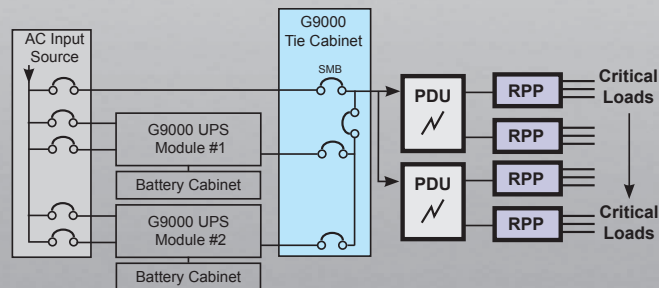

Maintenance Bypass Cabinet

Maintenance bypass cabinets are available in wall mount and stand-alone versions as well as a custom designed slim-line version that matches the height and depth of the G9000 to seamlessly blend with the UPS.

Power Distribution Unit/ Remote Power Panel

Optional Power Distribution Units (PDU) with internal 480/208 transformers and Remote Power Panels (RPP) are available in a range of sizes and capacities.